

# COLMAN

ENGINEERED AIR DISTRIBUTION

## SUPPLY GRILLES

### G SERIES

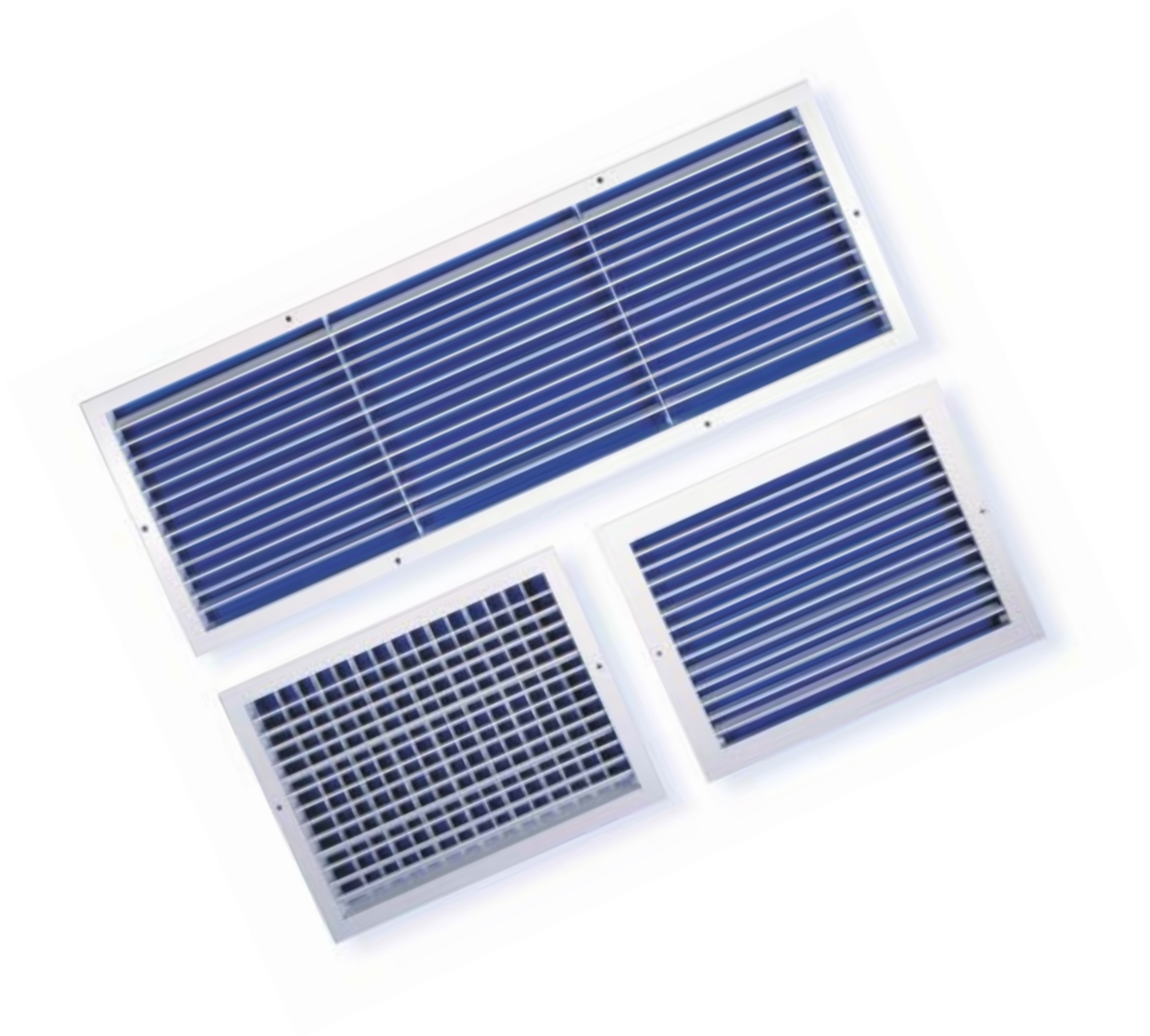

# G

SERIES

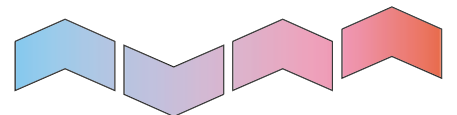

# SUPPLY GRILLES

## G SERIES

QUALITY AND EFFICIENCY WITHOUT COMPROMISE

### Application

Colman's range of Supply Grilles have been designed to compliment our extensive range of Return Air Grilles.

The range is suitable for side wall applications and is available in a wide variety of styles and sizes to suit individual application requirements.

### Description

With three standard frames and three styles of core, the range provides a flexible group of side wall grilles to meet most functional and installation requirements.

Grilles are manufactured with extruded aluminium flanges, and are complete with aluminium aerofoil blades, resulting in a clean aesthetic appearance.

Grilles utilising our 'B' style frame have integral cores which are retained by spring clips on the rear of the extrusion, whilst the 'H' style houses the core in a U channel panel frame, removable from the face and allowing access to the duct without having to remove the whole grille.

For applications requiring an adjustable air pattern, our uniquely designed steel 'A' core assures rapid diffusion and a high rate of aspiration. The core can be reversed and inverted in order to select either an upward or downward air pattern of 5 or 15 degrees.

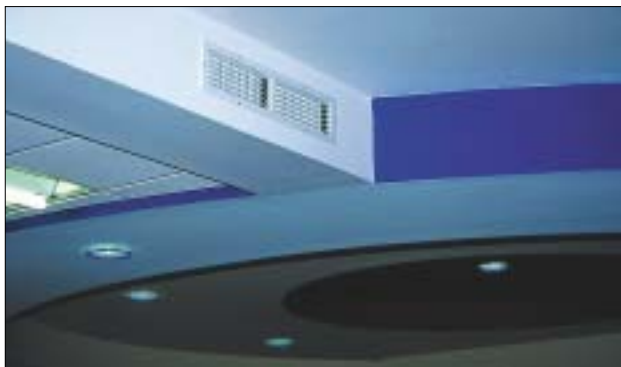

*All models are available with opposed blade volume control dampers operable from the face of the grille and can also be supplied with a wide selection of plenum boxes.*

### Fixings

The most common method for fixing our range of Supply Grilles is screw fixing through the flange face (method G) or through the flange neck (method A). However, to suit the wide selection of products within this range a number of alternative standard fixings arrangements are available, see the product coding section of this brochure for additional information.

### Finish

Supply Grilles are available as standard in powder coated RAL 9010 Matt White. Grilles which are manufactured totally from aluminium are also available in a natural anodised finish.

Please refer to the product coding section of this brochure for a list of other standard finishes. Special finishes are available upon request.

All grilles are pre-treated utilising a six stage phosphate conversion process conforming to ISO 9171 prior to being powder coated in accordance with BS 6496.

# Options and Order Codes

## Supply Grilles

1	2 FRAME	3 CORE	4 ACCESSORIES	5 ARRANGEMENT	6 FIXING	7 FINISH
<b>G</b>	<b>0</b> Core Only <b>B</b> 32mm frame for fixed core <b>H</b> 25mm frame for removable core <b>U</b> U channel  Note See product data sheet for frame sizes.	<b>A</b> Steel A Core <b>B</b> Aluminium single deflection core <b>D</b> Aluminium double deflection core  Note 1. A core to be used only with B, H, U frames. 2. See product data sheet for frame sizes.	<b>0</b> None <b>V</b> Face operated volume control damper <b>X</b> Face operated volume control damper (painted matt black)  Note V and X not available on 'U' frame.	<b>0</b> None	<b>0</b> None <b>A</b> Screw fixing thro neck <b>D</b> Universal extended bracket <b>E</b> Spring clips <b>G</b> Screw fixing thro flange <b>H</b> Hanger bracket Ceur 1140 <b>U</b> Universal bracket <b>X</b> Extended hanger bracket  Note 1. Code D for grille with VCD's only. 2. D, E, H, U, X, to be used only with B frame.	<b>0</b> Mill Finish <b>F</b> RAL 9010 Matt White <b>A</b> Anodised <b>9</b> Satin Anodised <b>8</b> Matt Black <b>C</b> BS00E55 Gloss <b>H</b> BS00E55 Satin <b>D</b> BS00E55 Matt <b>E</b> RAL 9010 Gloss <b>G</b> RAL 9010 Satin <b>3</b> RAL 9006 Aluminium <b>1</b> Special colours  Note Code A and 9 with frames B, H, and cores B and D only.

Note: The items shown in red print above and below in the code example are the standard option for this product. Unless shown otherwise on any quotation or order the units will be supplied in this configuration.

## Example of Order Codes

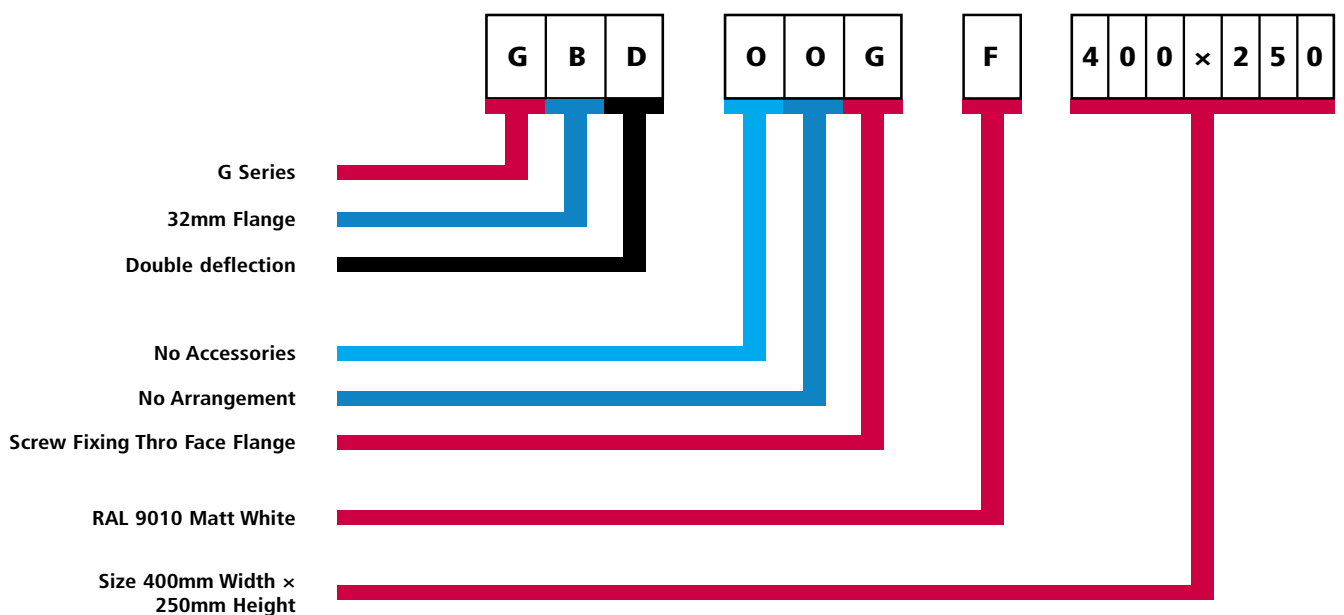

Plenum boxes are available for supply grilles dependant on size and application, please contact the sales office for details.

# Performance Data

## Models GBA, GHA, GBB & GBD

1. Data is based on a supply air temperature of 11°C below room air temperature and a room ceiling height of 2.7m.
2. Throw data is for sidewall applications using straight throw air patterns and with the centre line of the diffuser within 600mm of the ceiling.
3. When the centreline of the grille is within 300mm of the ceiling, the grille core should be arranged to provide a 5° upward discharge. When the grille is greater than 300mm away from the ceiling then the core should be arranged to provide a 15° upward deflection.
4. Adjustments of the vertical bars provide a wide variation in the horizontal air pattern with a corresponding reduction in throw. To enable selections to be made directly from the nomogram charts for variations in patterns and ceiling height, multiply the required throw by the appropriate factor from the following table. The performance chart can then be used directly to select a grille using this modified throw figure.
5. When a grille is installed so that the airstream is not influenced by "ceiling effect", the throw will be reduced by 40%. Multiply the required throw by 1.7 before applying the factor in paragraph 4. Use the grille mounting height in place of the ceiling height to select the appropriate factor.
7. Throw is the distance from the face of the grille to the opposite wall. If this distance is equal to the minimum throw of the grille the downwall velocity is approximately 0.4 m/s. If the distance is equal to the maximum throw of the grille the downwall velocity is approximately 0.15 m/s. This downwall velocity is measured at a location 1.5m from the floor and 150mm from the wall surface.
8. When two grilles are discharging towards each other, selections should be made so that the grilles will provide a maximum throw equal to half the distance between the two grilles to avoid excessive downdraught in the centre of the space.
9. The aspect ratio of a supply grille has a marked effect on the throw performance and the aspect ratio should not be altered without reference to the throw nomogram chart.
10. NC data are measured at a location 1.5 metres from floor level and at a 45° angle from the grille face with an 8dB deduction for room effect. Ratings for supply grilles are for a straight pattern. For a 45° widespread pattern an addition of 3dB will apply and for 90° widespread an addition of 7db will apply.
11. Dampers fitted to grilles are intended for fine balancing purposes. Excessive dampening to overcome high duct pressures will result in an increased sound level of approximately 8dB per doubling of pressure drop.
12. Pressure Drop Correction. For 45° widespread the pressure drop should be multiplied by 1.3. for 90° widespread the pressure drop should be multiplied by 2.5.

		Throw Factors					
		Ceiling Height (m)					
Air Pattern		2.7	3.0	3.3	3.6	3.9	4.2
Straight		1.00	1.05	1.10	1.15	1.20	1.25
GBD ONLY	Widespread 45°	1.30	1.37	1.44	1.53	1.62	1.73
	Widespread 90°	1.82	1.91	2.00	2.13	2.26	2.41

6. Grilles with straight throw air patterns should be spaced so that a minimum distance of one-third of the required throw exists between adjacent grilles to avoid interference between airstreams. The minimum distance between widespread grilles should be equal to the required throw.

# Selection Nomogram

## GBA, GHA Supply Grilles

### Selection Nomogram for GBA, GHA Supply Grilles

THROW CORRECTION FOR ASPECT RATIO = WIDTH ÷ HEIGHT = ASPECT RATIO  
 FACTOR x THROW EQUALS ACTUAL THROW

ASPECT RATIO	FACTOR	ASPECT RATIO	FACTOR	ASPECT RATIO	FACTOR
1	1.75	4.5	1.04	8	0.84
1.5	1.54	5	1.00	8.5	0.82
2	1.39	5.5	0.96	9	0.80
2.5	1.29	6	0.94	9.5	0.78
3	1.20	6.5	0.91	10	0.76
3.5	1.14	7	0.88	10.5	0.75
4	1.08	7.5	0.86	11	0.75

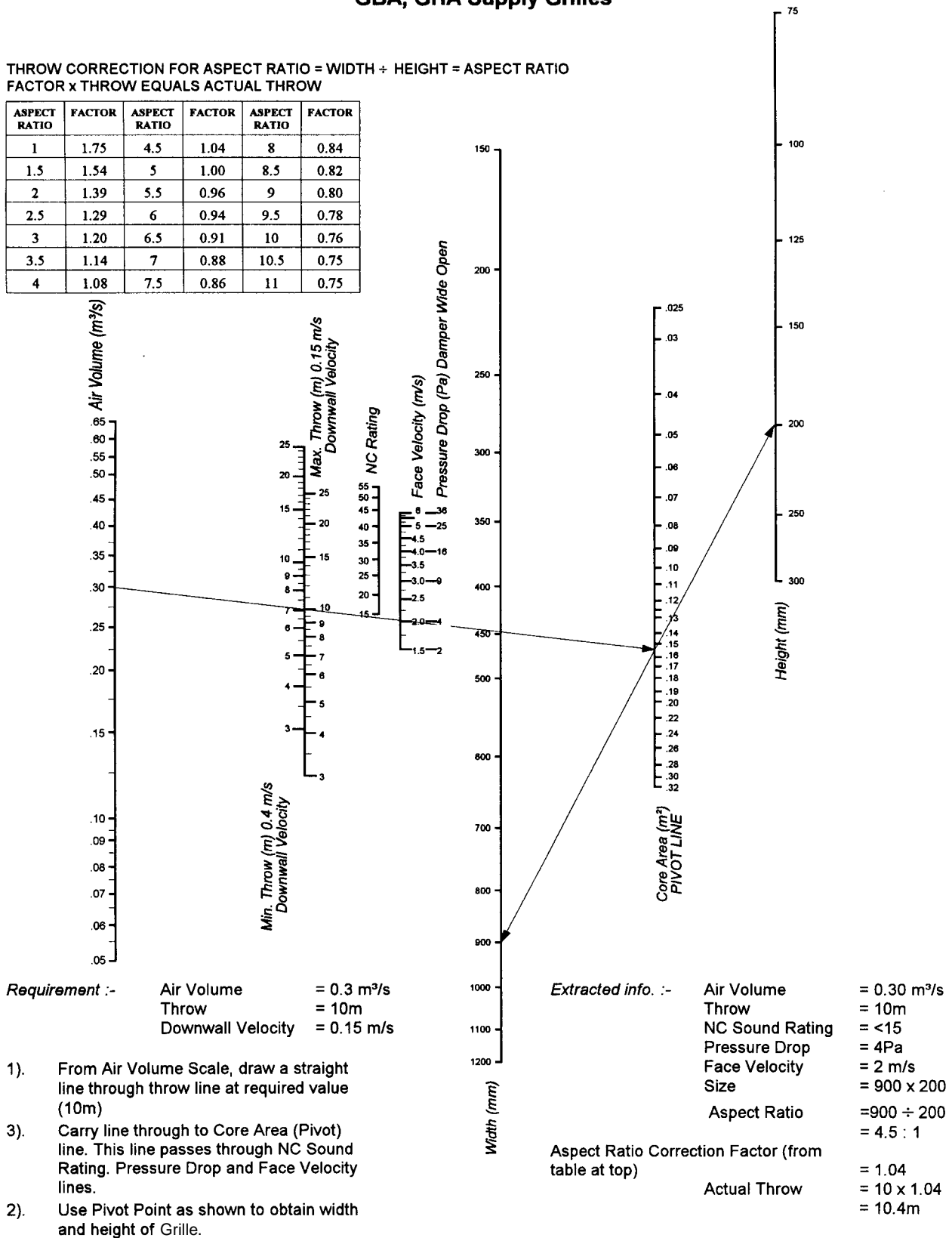

The above information applies to ceiling height of 2.7m. Information is based on a supply Air Temperature of 11 °c below room temperature.

# Select Nomogram

## GBB & GBD Sidewall Grilles

### Selection Nomogram for GBD Double Deflection Sidewall Grilles & GBB Single Deflection Sidewall Grilles

THROW CORRECTION FOR ASPECT RATIO = WIDTH + HEIGHT = ASPECT RATIO  
FACTOR x THROW = ACTUAL THROW

ASPECT RATIO	FACTOR	ASPECT RATIO	FACTOR	ASPECT RATIO	FACTOR
1	1.75	4.5	1.04	8	0.84
1.5	1.54	5	1.00	8.5	0.82
2	1.39	5.5	0.96	9	0.80
2.5	1.29	6	0.94	9.5	0.78
3	1.20	6.5	0.91	10	0.76
3.5	1.14	7	0.88	10.5	0.75
4	1.08	7.5	0.86	11	0.75

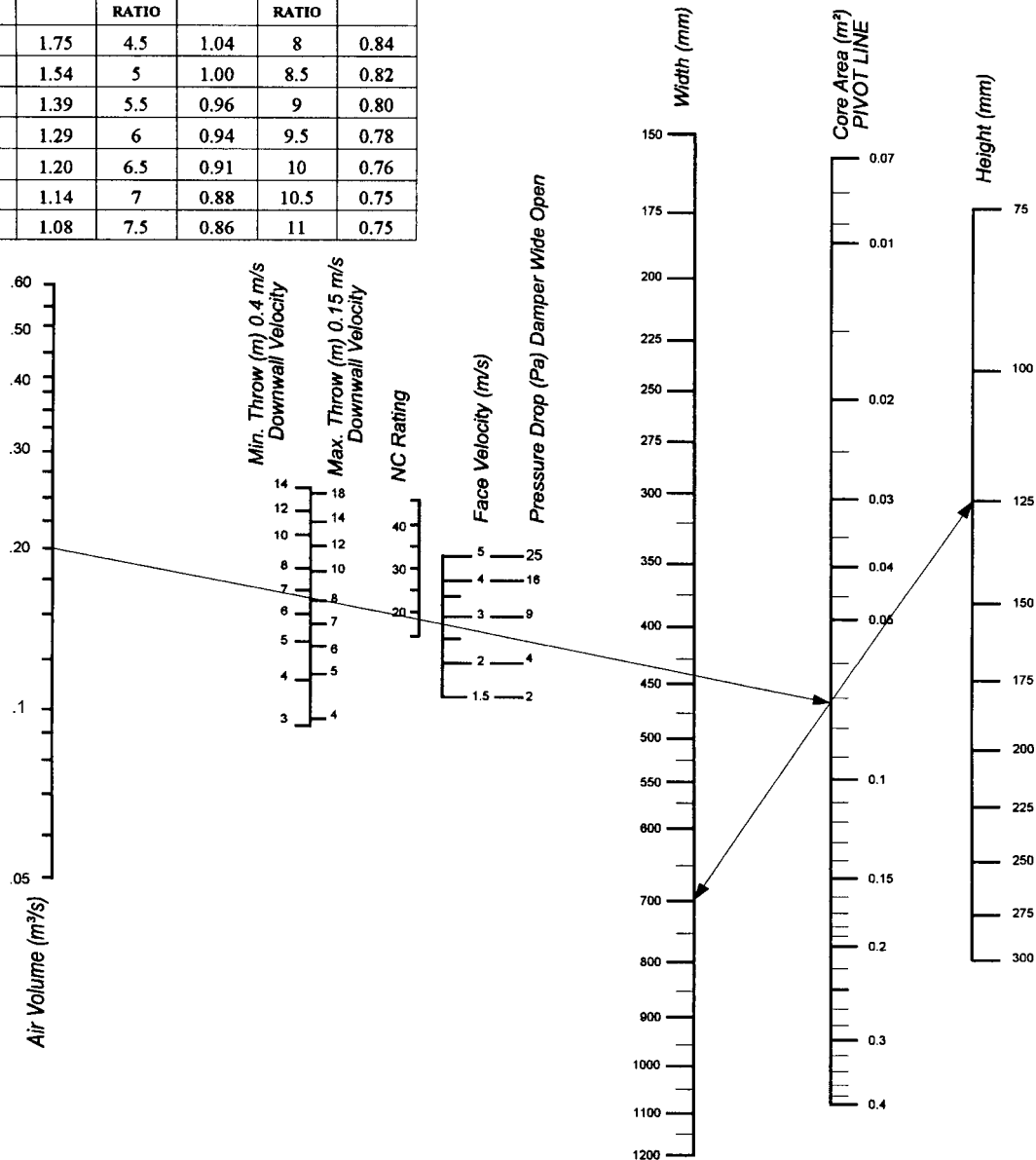

**Requirement :-**  
Air Volume = 0.2 m<sup>3</sup>/s  
Throw = 8.0m  
Downwall Velocity = 0.15 m/s

**Extracted info. :-**  
Air Volume = 0.20 m<sup>3</sup>/s  
Throw = 8.0m  
NC Sound Rating = <20  
Pressure Drop = 8Pa  
Face Velocity = 2.75 m/s  
Size = 700 x 125  
Aspect Ratio = 700 ÷ 125 = 5.6 : 1

- From Air Volume Scale, draw a straight line through throw line at required value (8.0m)
- Use Pivot Point as shown to obtain width and height of Grille.
- Carry line through to Core Area (Pivot) line. This line passes through NC Sound Rating, Pressure Drop and Face Velocity lines.

Aspect Ratio Correction Factor (from table at top) = 0.96  
Actual Throw = 8.0 x 0.96 = 7.7m

The above information applies to ceiling height of 2.7m. Information is based on a supply Air Temperature of 11 °c below room temperature.

# Core Areas (m<sup>2</sup>)

B & H Frame								
Grille Width (mm)	Height (mm)							
	75	100	150	200	250	300	350	400
150	.007	.011	.016	-	-	-	-	-
200	.009	.014	.023	.032	-	-	-	-
250	.012	.018	.029	.041	.052	-	-	-
300	.015	.022	.036	.049	.063	.077	-	-
350	.017	.026	.042	.058	.075	.091	.108	-
400	.020	.029	.048	.067	.086	.105	.124	.143
450	.023	.033	.055	.076	.098	.119	.140	.161
500	.025	.037	.061	.085	.110	.133	.156	.181
550	.028	.041	.068	.094	.120	.147	.173	.199
600	.031	.045	.074	.103	.132	.161	.189	.218
650	.033	.049	.080	.112	.143	.174	.206	.237
700	.036	.053	.087	.121	.154	.189	.222	.256
750	.038	.057	.093	.129	.166	.202	.239	.275
800	.041	.061	.099	.138	.177	.216	.255	.294
850	.044	.064	.106	.147	.189	.230	.271	.313
900	.046	.068	.112	.156	.200	.244	.288	.332
950	.049	.072	.119	.165	.211	.258	.304	.351
1000	.052	.076	.125	.174	.223	.272	.321	.369
1050	.054	.080	.131	.183	.234	.286	.337	.388
1100	.057	.084	.138	.192	.246	.299	.353	.407
1150	.060	.088	.144	.201	.257	.313	.370	.426
1200	.062	.092	.151	.209	.268	.327	.386	.445



# Dimensional Data

## Supply Grilles

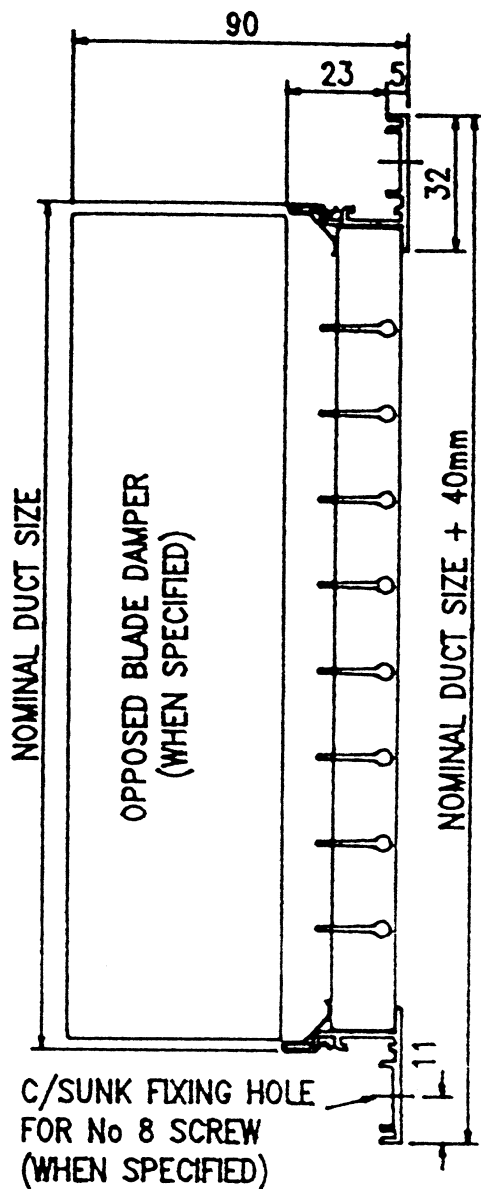

### GBB

A single deflection grille with individually adjustable aluminium blades in the horizontal plane held captive within an extruded aluminium outer frame.

MINIMUM SIZE	150 × 75
MAXIMUM SIZE	1200 × 1200
MAXIMUM INDIVIDUAL CORE SIZE	400 × 600

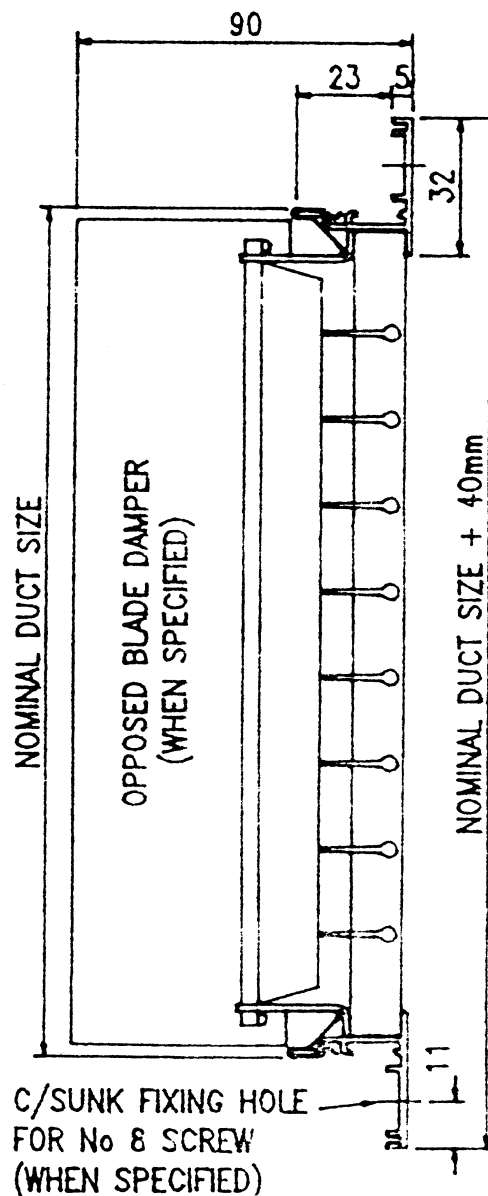

### GBD

A double deflection grille with individually adjustable aluminium blades in both horizontal and vertical planes held captive within an extruded aluminium outer frame.

MINIMUM SIZE	150 × 75
MAXIMUM SIZE	1200 × 1200
MAXIMUM INDIVIDUAL CORE SIZE	400 × 600



# Dimensional Data

## Supply Grilles

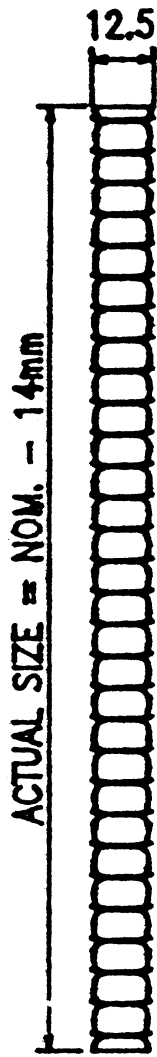

### GOA

A unique double deflection steel core assembly giving an optional 5° or 15° horizontal air pattern with adjustable tamperproof straight to widespread air pattern.

MINIMUM SIZE 136 × 61  
MAXIMUM SIZE 1186 × 386

Note: Only available in 25mm increments on base sizes.

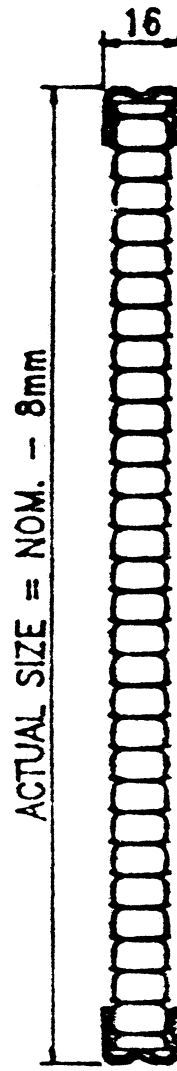

### GUA

Compromises of a GOA core assembly fixed into a steel U channel frame.

MINIMUM SIZE 142 × 67  
MAXIMUM SIZE 1192 × 392

Note: Only available in 25mm increments on base sizes.

# Dimensional Data

## Supply Grilles

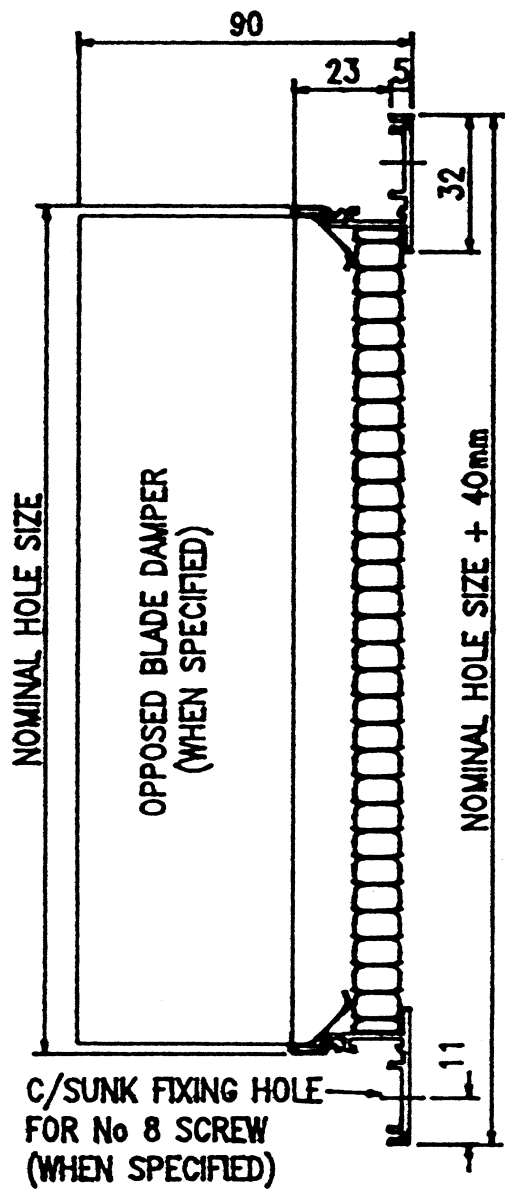

### GBA

A double deflection grille comprising the GOA core assembly held captive within an extruded aluminium outer frame.

MINIMUM SIZE	150 × 75
MAXIMUM SIZE	2400 × 1200
MAXIMUM INDIVIDUAL CORE SIZE	1200 × 400 NOM.

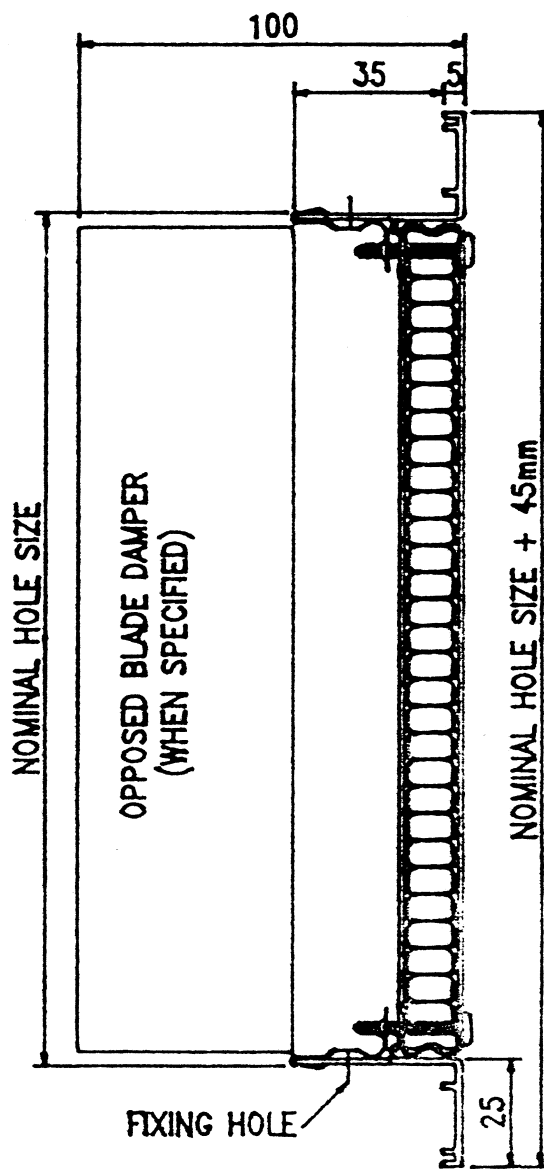

### GHA

A double deflection grille comprising a GUA core assembly fitted into an extruded aluminium outer frame such that it can easily be removed.

MINIMUM SIZE	150 × 75
MAXIMUM SIZE	2400 × 1200
MAXIMUM INDIVIDUAL CORE SIZE	1200 × 400 NOM.

# Air Pattern Adjustment

## Model GOA

### GOA

Manufactured from high quality steel with a free area of 85.6% type GOA adjustable grille provides a maximum adjustment of air patterns within an acceptable range. A simple yet tamperproof key setting of vertical fins provides a variation from straight to widespread pattern.

The type 'A' core can be reversed and inverted in order to select a variation in horizontal air patterns of either 5° or 15° as illustrated.

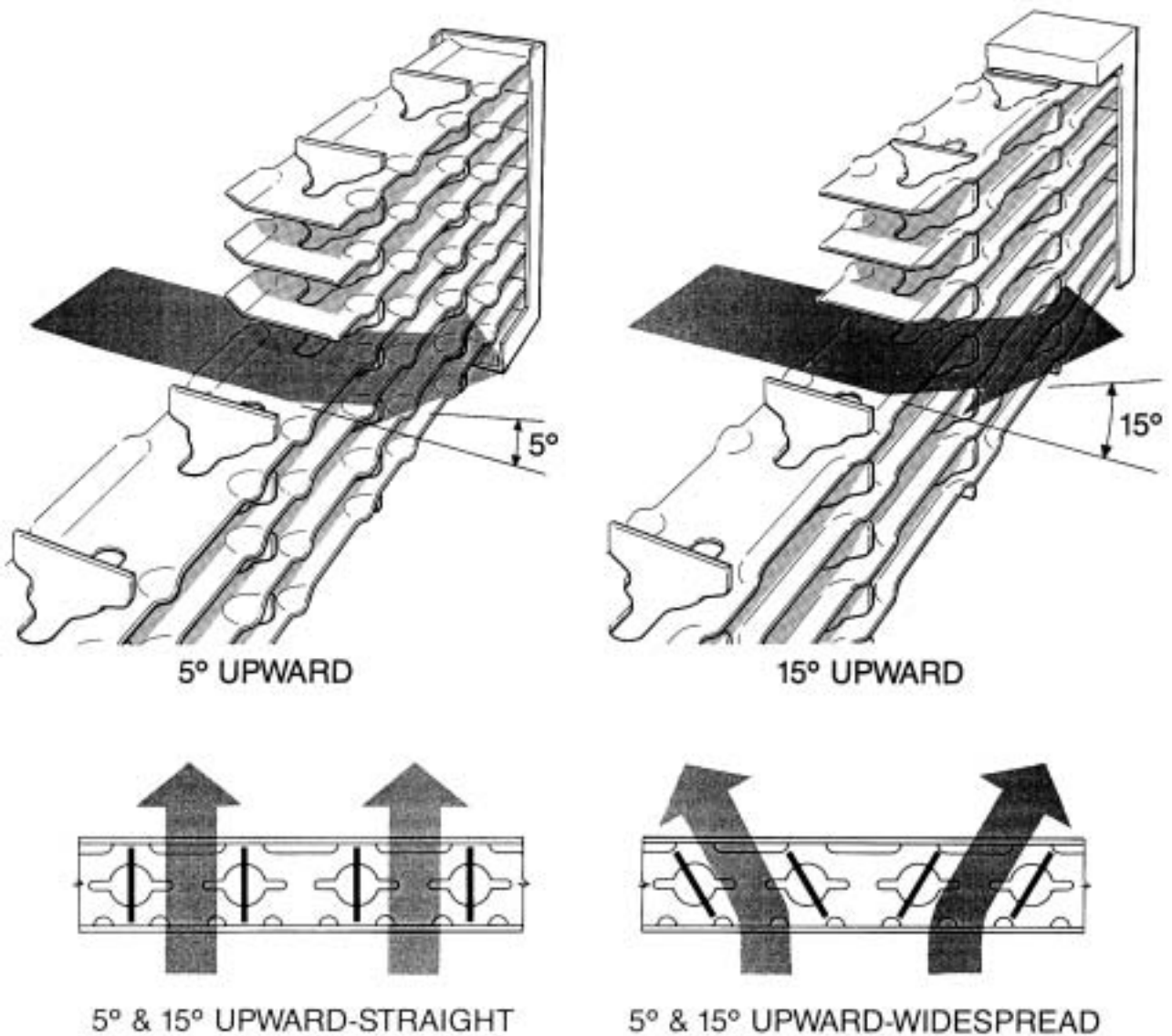

## PRODUCT RANGE

AIR HANDLING UNITS

PACKAGED AIR CONDITIONING UNITS

SPLIT SYSTEM AIR CONDITIONING UNITS

### TERMINAL PRODUCTS

Fan Coil

VAV

Constant Volume

Induction

Fan Assisted VAV

HEAT RECOVERY PLANT

HEAT PUMPS

CONTROL SYSTEMS

REFRIGERATION

DAMPERS

FILTERS

### DIFFUSERS

Linear Slot

Louvre Face

Sidewall

Perforated Face

Vee Face Two Way

Circular

Swirl

Ceiling

Sidewall

Single and Double Deflection

Sidewall Fixed and Adjustable

Jet Flow

### ACOUSTIC PRODUCTS

Attenuators

### DISPLACEMENT

### GRILLES

Linear Bar

Ceiling

Sidewall

Floor

Computer Floor

Cill

Single and Double Deflection

Egg Crate

Hinged Core

Door Transfer

Security and Prison

### LOUVRES

External

Circular

Door

Screens

Penthouse

Acoustic



Air Distribution and Air Handling

Oldfields Business Park

Birrell Street, Fenton

Stoke-on-Trent ST4 3ES

Telephone: +44 (0)1782 599995

Facsimile: +44 (0)1782 332092

email: [colman.moducel@eaton-williams.com](mailto:colman.moducel@eaton-williams.com)



Station Road, Edenbridge  
Kent TN8 6EG, England  
Telephone: +44 (0)1732 866055  
Facsimile: +44 (0)1732 869626  
[www.eaton-williams.com](http://www.eaton-williams.com)